

Ferrolli



Force B

High power modular generator for indoor and outdoor installation



MODULAR POWER

For new buildings and high-power upgrades



FORCE B is a family of high-power condensation modular generators designed to fully meet design requirements in the field of new buildings and upgrades of central heating systems.

FORCE B range generators can be installed individually or with up to four cascade modules for a maximum overall power of 600 kW.

The technical and construction features are in line with the highest standards requested by professionals in the central heating systems industry.

The efficiency of the FORCE B range enables the purchaser to apply for current tax benefits to upgrade climate-control systems.

THE RANGE

3 generators, certified **B23**, with an open chamber and forced draught

mod. B 80

HEAT INPUT 74.4 KW

EFFECTIVE HEATING OUTPUT (50°C-30°C) 77.0 KW

MAX P EFFICIENCY (50°C-30°C) 103.5

mod. B 150

HEAT INPUT 143 KW

EFFECTIVE HEATING OUTPUT (50°C-30°C) 148 KW

MAX P EFFICIENCY (50°C-30°C) 103.5

mod. B 120

HEAT INPUT 113.0 KW

EFFECTIVE HEATING OUTPUT (50°C-30°C) 117 KW

MAX P EFFICIENCY (50°C-30°C) 103.5



CHARACTERISTICS

Product benefits

- > **High power thermal condensing floor standing module.**
- > Modular insulated painted cabinet structure (IPX5D), vertical layout **with single combustion unit.**
Complete as standard of hydraulic, gas and flue gas system for bank installation, with 2, 3 and 4 modules
- > Designed for outdoor installation in single configuration or in banks up to 600 kW
- > Heat exchanger with pre-assembled elements in **aluminium-silicon alloy** designed to achieve maximum exchange efficiency and low pressure drops on the water circuit
- > Full pre-mixing **combustion unit** with metal fibre micro-flame burner with very low polluting emissions (**Class 6 according to EN 15502-1**). The modules can run on Methane and LPG
- > Generator protection systems:
 - * Double sensor (delivery and return) system for operation at **ΔT constant** (adjustable from 0 to 60°C)
 - * Exchanger overtemperature protection sensor calibrated at 95°C
 - * Flue gas safety sensor
 - * Water pressure switch with minimum threshold of 0.8 bar
- > Hydraulic unit (provided as an accessory) with three-way shut-off valve for discharge into the atmosphere and option of choosing between two **circulators, standard and high head**
- > Air / Flue gas circuit with intake in the installation site and **check valve** on the flue gas ejection duct to size the pressurised manifold
- > Module bank management with **self-configuring Master / Slave system** and option of setting the generator on/off sequence
- > Electronics on board machine to manage a **system with two direct zones and one DHW storage** or systems with differentiated temperatures (direct and mixed) in combination with the FZ4 B temperature control unit
- > **Range Rated** certified generator to adjust the generated power to the system's needs by increasing the efficiency of the system and preserving the mechanics of the machine
- > The modules can be controlled and operated remotely:
 - * Power or temperature adjustment with 0 - 10V signal
 - * Blocking alarm signal for safety and to restart operation
 - * **Opentherm (OT) and Modbus** communication protocols with settable parameters

THE PRODUCT IN BRIEF



Device suitable for operation in a **partially protected place** with a minimum temperature of -5°C, as standard



Appliance certified as "**range rated**" according to UNI EN 483



Cascade operation



Remote control of boiler parameters via remote control



Device operates with **climatic control** and sliding system temperature (optional external temperature probe)



Minimum polluting emissions (**class 6 according to EN 15502-1**) as required by Directive ErP of 26.09.2018 (NOx emissions < 56mg/kWh)



FORCE B

Components

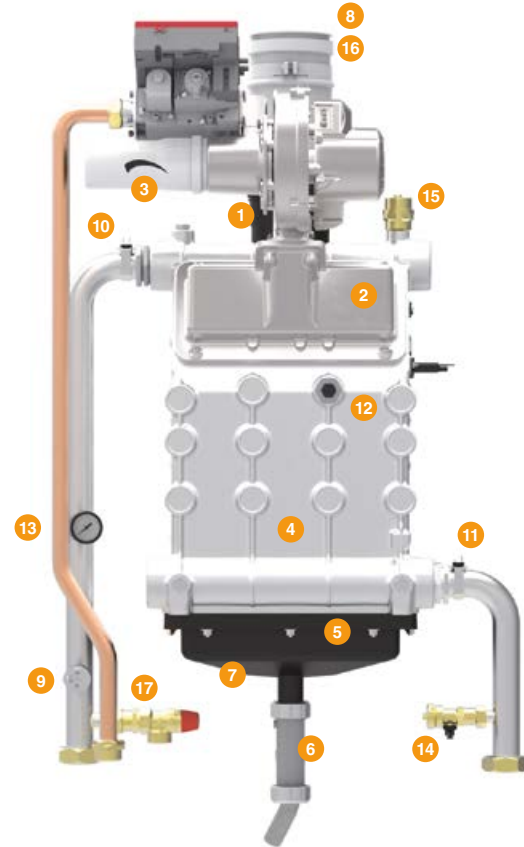

- 1** Pre-mixing unit
- 2** Burner
- 3** SILENCER The combustion unit can operate with Methane, LPG and Propane air with conversion kits that can be installed by authorised service technicians. The pre-mixing unit, combined with the low NOx micro-flame burner, has allowed for the Class 6 certification of the generator in accordance with UNI 15502-1
- 4** Aluminium heat exchanger in AL/Si alloy single block obtained by die-casting. The water passages inside the heat exchanger are particularly wide to ensure low pressure drops. Completely wet combustion chamber integrated in the casting
- 5** Condensate collection manifold
- 6** Condensate discharge
- 7** Flue gas safety sensor 110°C
- 8** SWING CHECK VALVE A thermostat calibrated at 110°C has been installed on the flue gas manifold to ensure perfect operation of the flue gas exhaust together with a swing check valve with a gravity damper that prevents flue gas return into the boiler. Appliances provided with this device enable design engineers to size the pressurised flue gas channel
- 9** Water pressure switch min 0.8 bar
- 10** System delivery temperature sensor
- 11** System return temperature sensor
- 12** HEAT EXCHANGER OVER-TEMPERATURE SAFETY SENSOR The heat exchanger's operating temperature is checked by three independent sensors that are positioned in three different detection points. This ensures maximum safety during operation and protects the heat exchanger, increasing its service life.
- 13** Pressure gauge (the pressure can also be read on the display)
- 14** Boiler drain cock
- 15** Air bleed valve
- 16** Combustion analysis outlet
- 17** Safety valve 6 bar
- 18** Flow manifold DN 65
- 19** Return manifold DN 65
- 20** Inlet gas manifold DN 40
- 21** Condensate drain manifold
- 22** Circulation pump (7 mt)
- 23** Hydraulic group

CHARACTERISTICS

Control panel

Characterised by a large dot matrix display and keys to set the basic functions of the generator and to select the parameterisation menus.

The interface is designed to make it easier to read the parameters and browse the menus, both for the USER to adjust and set the basic functions and the TECHNICIAN for maintenance and advanced parameters.

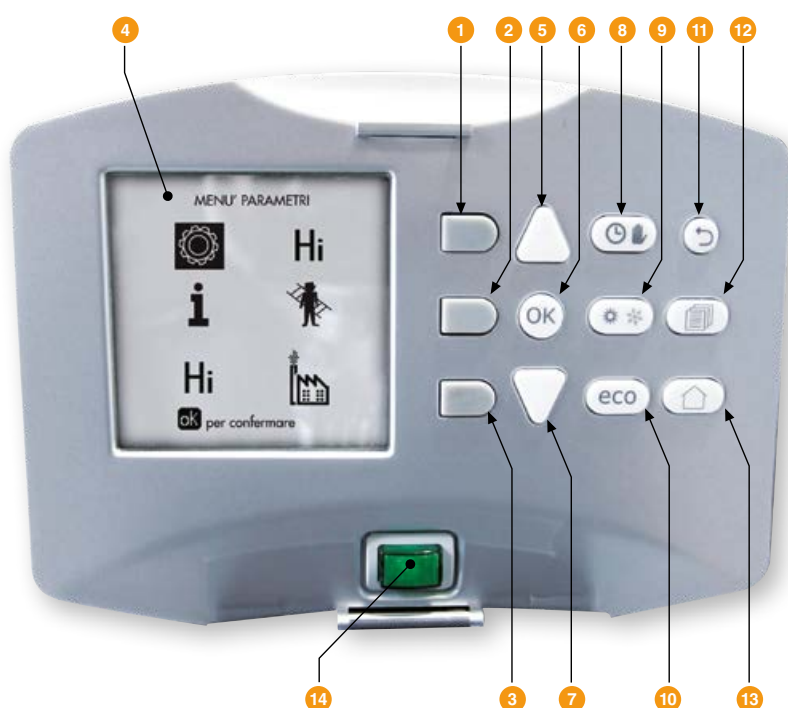

KEY

- 1 Contextual key 1
- 2 Contextual key 2
- 3 Contextual key 3
- 4 Dot matrix display (example of main screen)
- 5 Menu navigation key
- 6 Menu input/confirmation key
- 7 Menu navigation key
- 8 DHW/heating Manual/Automatic operation key
- 9 Summer/Winter mode selection key
- 10 Economy/Comfort mode selection key
- 11 Menu exit key
- 12 Main menu key
- 13 Home key (back to the main screen)
- 14 Main switch

CONTEXTUAL KEYS (part. 1, 2, 3) are grey, have no silk-screen printing and can have a different meaning based on the selected menu. It is essential to follow the indications provided by the display (icons and text). For example, by using contextual key 2 (part. 2), it is possible to access information about the device, such as: the temperature of the sensors, the operating power, etc.

DIRECT KEYS (part. 8, 9, 10) always have the same function

MENU/NAVIGATION KEYS

The menu/navigation keys (part. 5, 6, 7, 11, 12, 13) are used to scroll through the various menus implemented in the control panel

Two distinct levels of parameterisation can be accessed from the control panel's main menu:

USER level

Since it is not password-protected, it enables the "system manager" to set the operating mode of the single or cascade generator in order to sync them as much as possible with the type of system based on user requirements

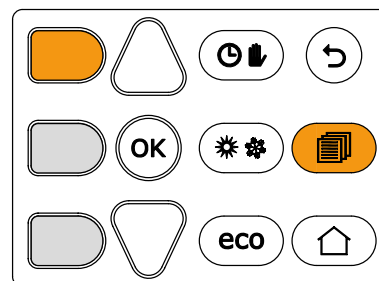

TECHNICIAN level

Since it is password-protected, it enables the "authorised technician" to check and modify the thresholds of each single component of the generator and boiler system.

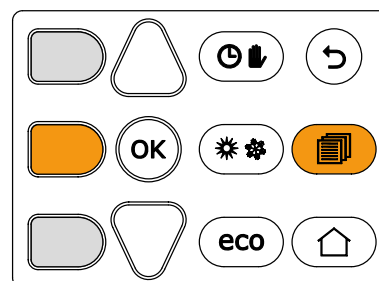



CHARACTERISTICS

Control electronics

For all "PROFESSIONAL" range high-power condensation heat exchangers, Ferroli uses a single electronic platform and the same interface panel that is able to manage correct operation and safety of the generator, cascade installation and the main components of a heating system for domestic hot water production.

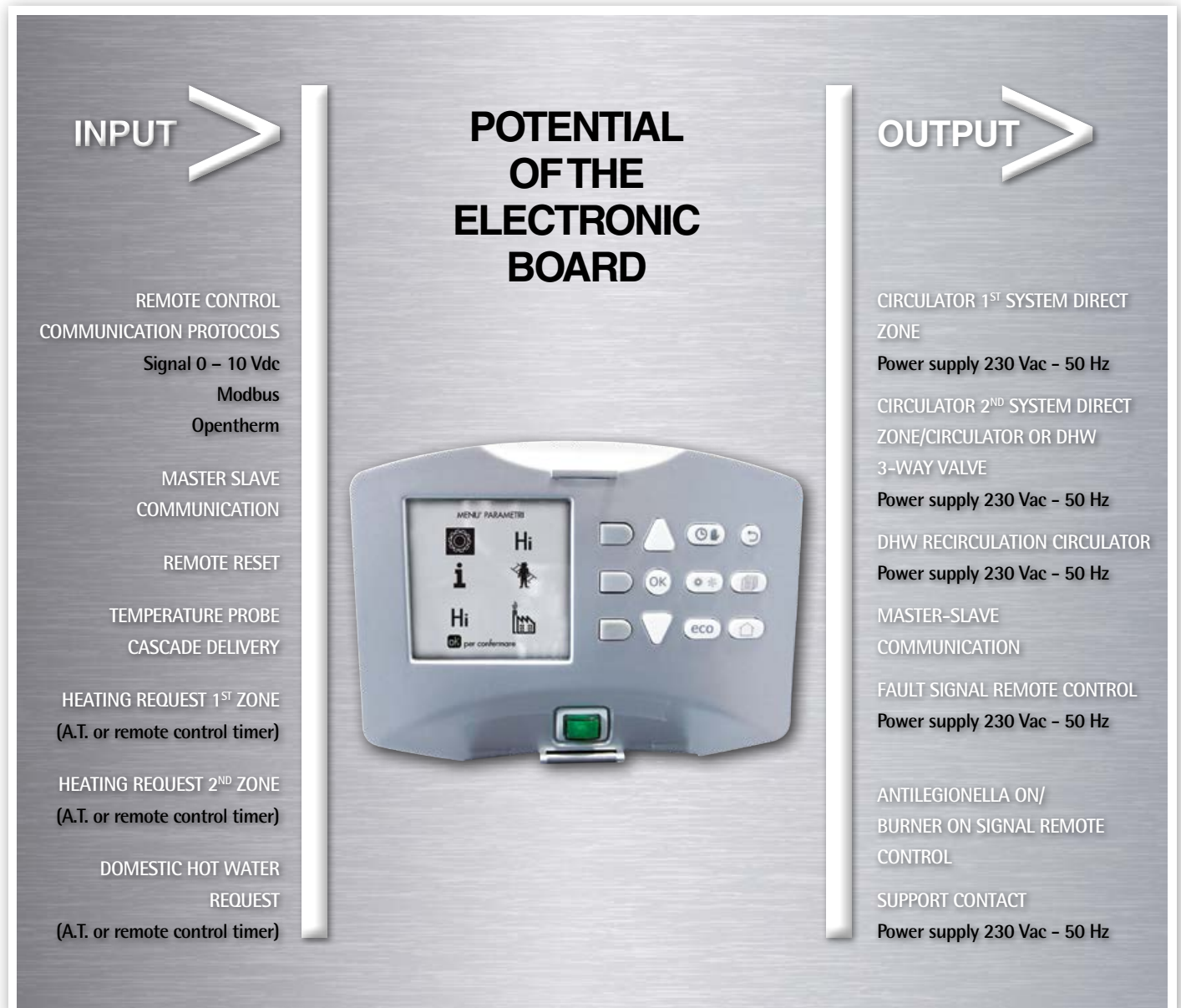

KEY (referred to the diagrams on the next page)

32 Boiler circulator **72a** Room thermostat 1st zone (mixed) **72b** Room thermostat 2nd zone (mixed) **72c** Room thermostat 3rd zone (direct) **138** External probe **139a** Remote timer control 1st zone (mixed) **139b** Remote timer control 2nd zone (mixed) **139c** Remote timer control 3rd zone (direct) **155** Storage tank probe **300** Antilegionella circulator **315a** Mixing valve 1st zone (mixed) [A = OPENING PHASE B = NEUTRAL C = CLOSING PHASE] **315b** Mixing valve 2nd zone (mixed) [A = OPENING PHASE B = NEUTRAL C = CLOSING PHASE] **317a** Safety thermostat 1st zone (mixed) **317b** Safety thermostat 2nd zone (mixed) **318a** Circulator 1st zone (mixed) **318b** Circulator 2nd zone (mixed) **318c** Circulator 3rd zone (direct) **319a** Delivery sensor 1st zone (mixed) **319b** Delivery sensor 2nd zone (mixed) **a** 1st zone (mixed) **b** 2nd zone (mixed) **c** 3rd zone (direct) **d** Storage tank circuit **FZ4 B** Zone control card **PHE** Steel plate heat exchanger



CHARACTERISTICS

Control electronics

In the event of Force B installation in a direct two-zone system (such as a heating circuit and DHW production), the standard electronics can manage the system autonomously without using any optional external equipment. With regard to mixed systems with high and low operating temperature, the boiler must be coupled with the FZ4 B temperature control module designed to manage a heating system up to three zones, two of which mixed.

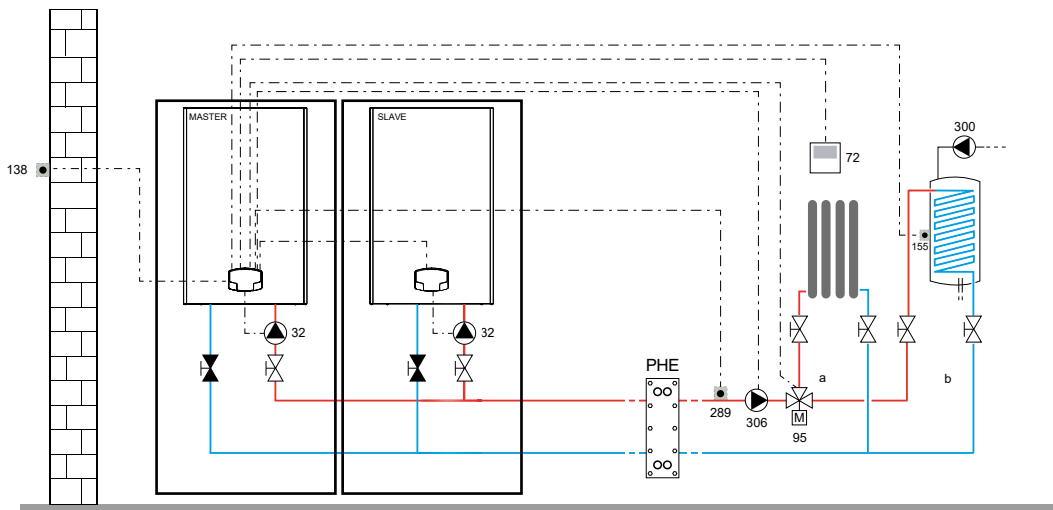

CASE A: REPLACEMENT OF THE EXISTING GENERATOR ON A HIGH TEMPERATURE SYSTEM

Thermal system with two loops separated by a plate heat exchanger (PHE). The primary circuit is fed by two Force B modules connected as a bank operating in AUTO-CASCADE mode managed directly by the boiler electronics. A “direct” high temperature circuit and a DHW storage with recirculation pump are connected on the secondary circuit (system side).

In addition to SLAVE thermal unit management, without any additional equipment, the MASTER generator can control the system's main components.

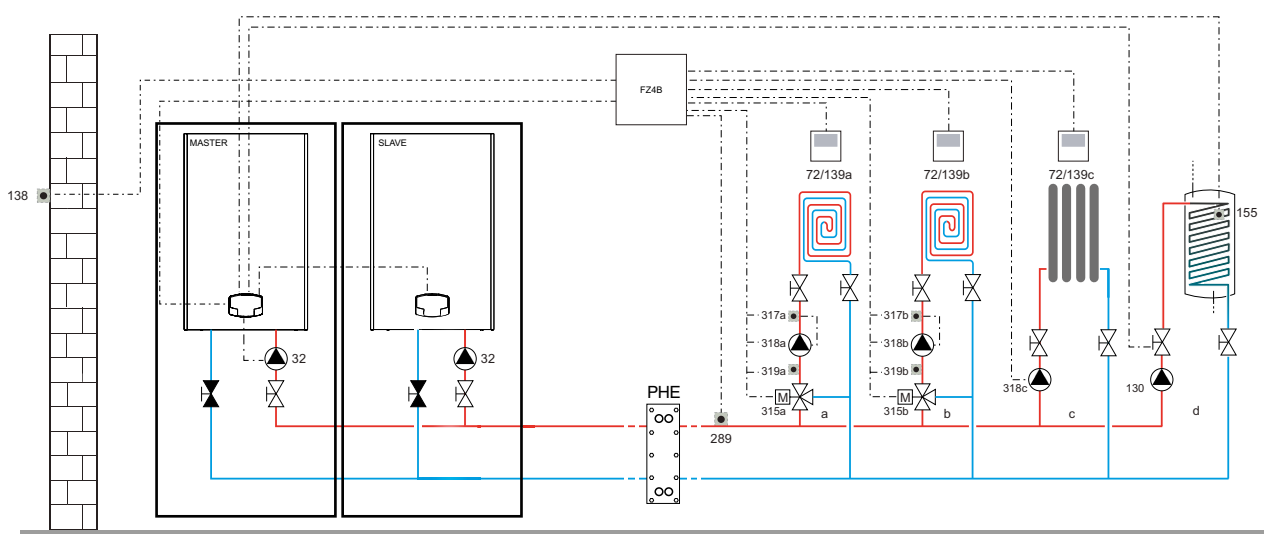

CASE B: NEWLY DESIGNED SYSTEM

Thermal system with two loops separated by a plate heat exchanger (PHE). The primary circuit is fed by two Force B modules connected as a bank operating in AUTO-CASCADE mode managed directly by the boiler electronics. The secondary circuit is composed of two mixed low temperature “zones”, a high temperature direct one and a DHW storage. The MASTER generator controls DHW production directly, in addition to managing the SLAVE thermal unit. The heating zones are controlled by card FZ4 B, connected to the generators through Open Therm.



TECHNICAL DATA

Dimensions and summary table

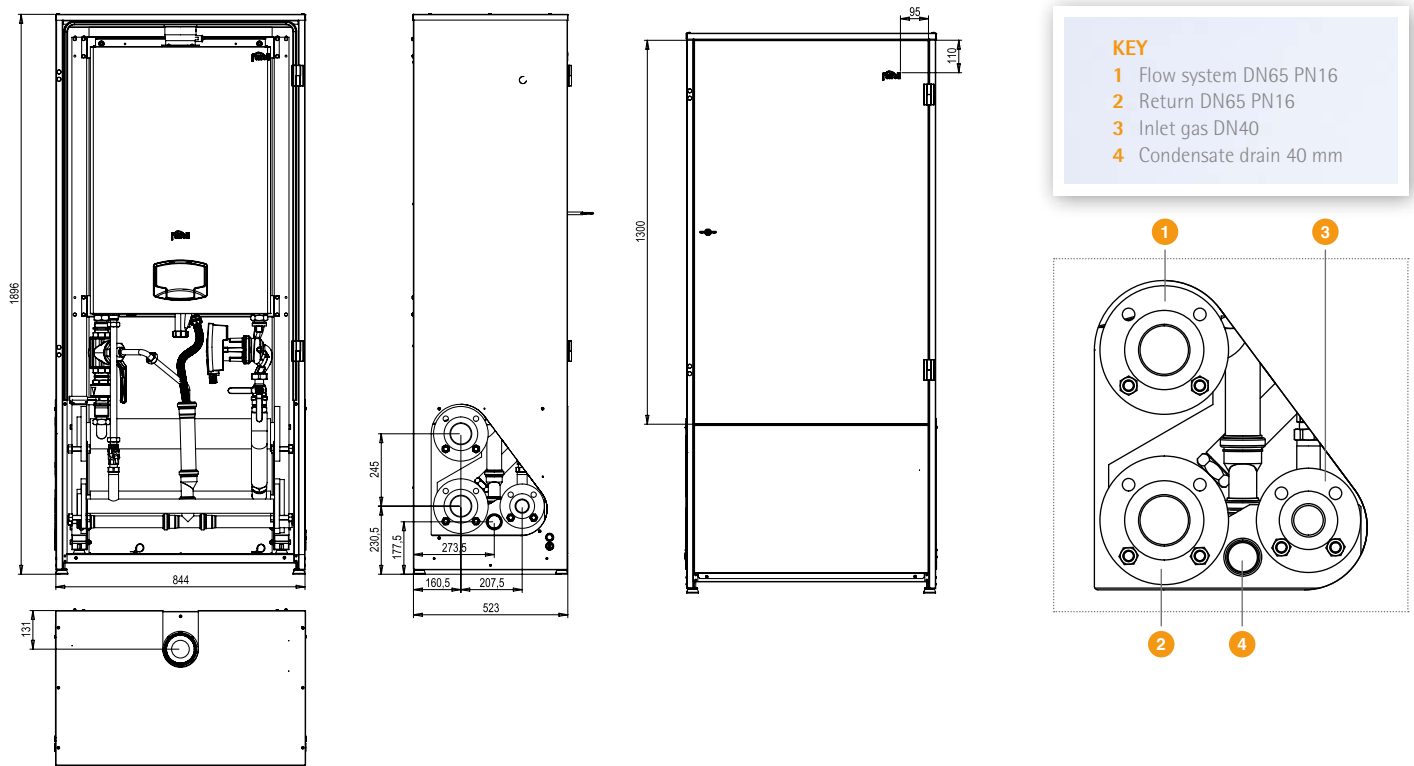

FORCE		B 80	B 120	B 150
Fuel			MTN / LPG	
Heating max heat input	kW	74.4	113	143
Heating min heat input	kW	15	19	24
Heating max heat output (80/60°C)	kW	72.9	110.5	140
Heating min heat output (80/60°C)	kW	14.7	18.7	23.6
Heating max heat output (50/30°C)	kW	77	117	148
Heating min heat output (50/30°C)	kW	16.3	20.5	25.9
MaxP efficiency (80/60°C)	%	98	97.8	97.8
MinP efficiency (80/60°C)	%	98.3	98.3	98.3
MaxP efficiency (50/30°C)	%	103.5	103.5	103.5
MinP efficiency (50/30°C)	%	108.5	108	108
Efficiency 30%	%	108.6	108.1	108.1
NOx emissions class	-	6	6	6
NOx (O ₂ =0%) weighted	mg/kWh	54	38	40
MaxP flue gas temperature (80/60°C)	°C	70	72	73
MinP flue gas temperature (80/60°C)	°C	60	60	60
MaxP flue gas temperature (50/30°C)	°C	48	54	54
MinP flue gas temperature (50/30°C)	°C	30	30	30
MaxP flue gas flow rate	g/s	34	51	65
MinP flue gas flow rate	g/s	7	9	11
CO ₂ max G20	%	9.3	9.3	9.3
CO ₂ min G20	%	8.9	8.9	8.9
CO ₂ max G31	%	10.5	10.5	10.5
CO ₂ min G31	%	10	10	10
Max heating working pressure	bar	6	6	6
Min heating working pressure	bar	0.8	0.8	0.8
Max heating temperature	°C	95	95	95
Protection rating	IP		IPX4D	
Supply voltage	V/Hz		230/50	
Absorbed electric power	W	93	175	250
Heating water content	litres	4.2	5.6	6.7
Empty weight	kg	54	63	73



TECHNICAL DATA

Diagrams of boiler pressure drops

FORCE B 80 - FORCE B 120

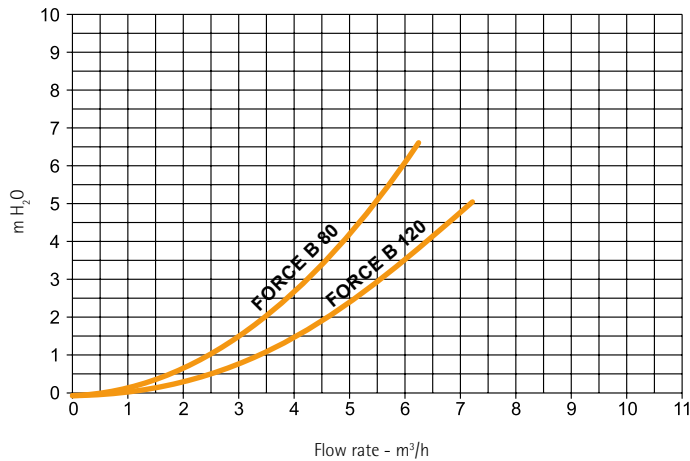

FORCE B 150

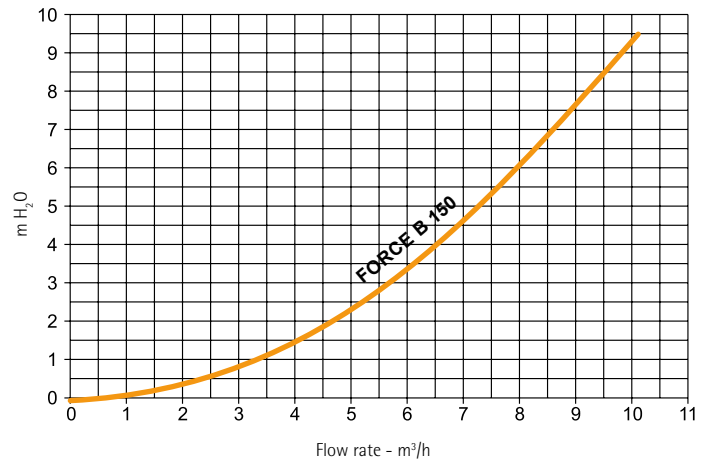

TECHNICAL DATA

Characteristic circulator head/flow rate curves

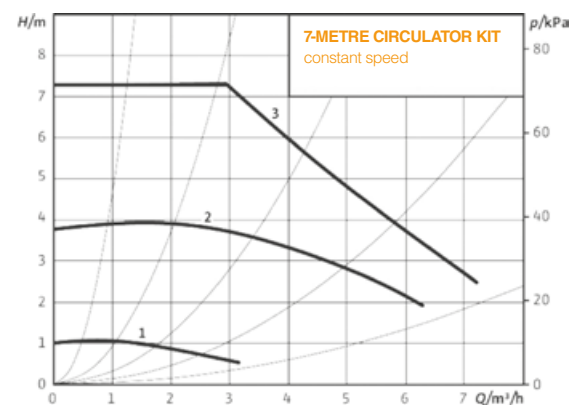
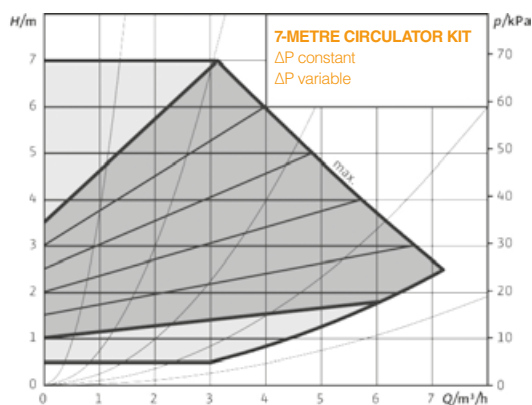
CIRCULATOR KIT
7 m



CASCADE INSTALLATION

Characteristics and strong points

The **Force B cascade system** has been designed by drawing from Ferroli's extensive experience in field of central heating generators and with feedback from design engineers and installers. All boiler parts have designed to **facilitate coil installation**. The generators are supplied (optional) with all the accessories for rapid, sound and safe **cascade central heating installation**:



- 1 The FORCE B range can be coupled in banks with 2, 3 and 4 generator combinations up to a maximum power of approximately 600 kW, with a modulation ratio up to 1:32.
- 2 The dimensions of generators and positioning of fittings are identical. All range models are perfectly interchangeable with each other.
- 3 The equipped box are design for the external installation and it's certificated IPX5D
- 4 FORCE B is fitted with a standard swing check valve that prevents flue gas return into the boiler. This device enables pressurised flue gas duct designs with much smaller and more cost-effective diameters.
- 5 The electronics fitted as per standard was designed to autonomously manage the dynamics of several generators in cascade, with MASTER-SLAVE logic, with maximum 6 generators.
- 6 By setting the parameters of the cascade MASTER board, the ignition sequence of the various modules can be set and rotated so as to evenly divide the number of operating hours.
- 7 Flue gas manifold as optional certificate for indoor installation.

GENERATORS				COIL MODULES	HEAT INPUT kW	HEAT OUTPUT		CASCADE MODULATION	
1	2	3	4			50 / 30°C kW	80 / 60°C kW	MinP - MaxP 50 / 30°C kW MinP / MaxP	
80	80			2	148,8	154	145,8	14,7 - 154,0	1:10
80	120			2	187,4	194	183,2	14,7 - 194,0	1:13
120	120			2	226	234	220,6	20,0 - 234,0	1:12
120	150			2	272	265	250,3	20,0 - 265,0	1:13
150	150			2	318	296	280	25,9 - 296,0	1:11
120	120	120		3	339	351	330,9	20,0 - 351,0	1:18
80	150	150		3	392,4	373	352,9	14,7 - 373,0	1:25
120	150	150		3	431	413	390,3	20,0 - 413,0	1:21
150	150	150		3	477	444	420	25,9 - 444,0	1:17
120	120	120	120	4	452	468	441,2	20,0 - 468,0	1:23
120	120	150	150	4	544	530	500,6	20,0 - 530,0	1:26
120	150	150	150	4	590	561	530,3	20,0 - 561,0	1:28
150	150	150	150	4	636	592	560	25,9 - 592,0	1:23



CASCADE INSTALLATION

Operating logic

The standard electronics installed on each Force B module can control a bank of 6 generators without using any optional additional control units.

The logic chosen by the design engineers is MASTER / SLAVE and, when duly connected, it ensures that all coils work as a single generator managed by a single control (MASTER) able to:

- Distinguish the number of generators installed and connected in bank and identify the system components connected to the MASTER generator terminal board.
- Modify the burner's ignition sequence independently in order to distribute the total number of operating hours equally.
- Using a specific parameter, it is possible to customise the switch-off logic of the bank generators (Parallel or Sequential), without the need to resort to optional sequence control units or to additional control modules.

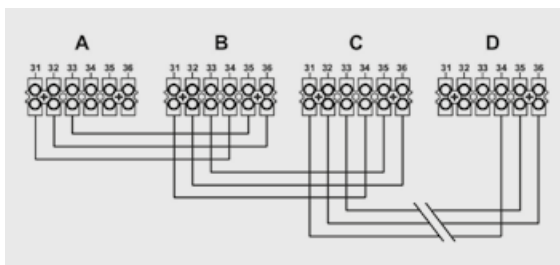

- A** 1st MASTER module
- B** 2nd SLAVE module
- C** 3rd SLAVE module
- D** 6th SLAVE module

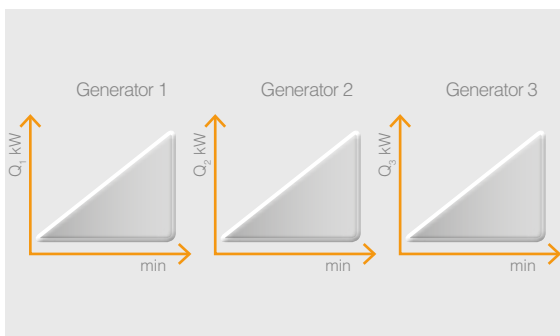

Parallel operation

Parallel operation of the modules provides for simultaneous ignition, power modulation and switch-off of the burners.

This solution allows for maximum system efficiency since most generators running at the lowest power enable maximum condensation.

The modulation range of the system's power is instead limited.

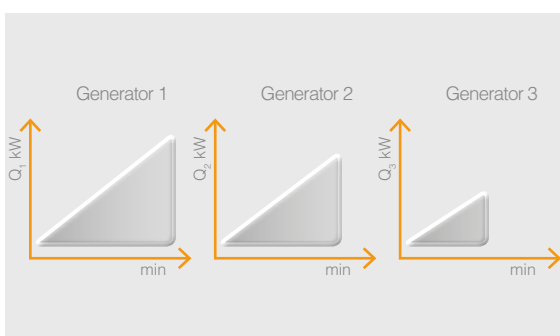

Sequential operation

The ignition and power modulation of the burners with sequential operation enable a wide modulation range that runs from minimum power of a single generator to a total maximum power of all burners running together.

This makes the system more flexible compared to the system's heating requirements, but at the expense of the loss of a certain degree of energy efficiency.



CASCADE INSTALLATION

Accessories

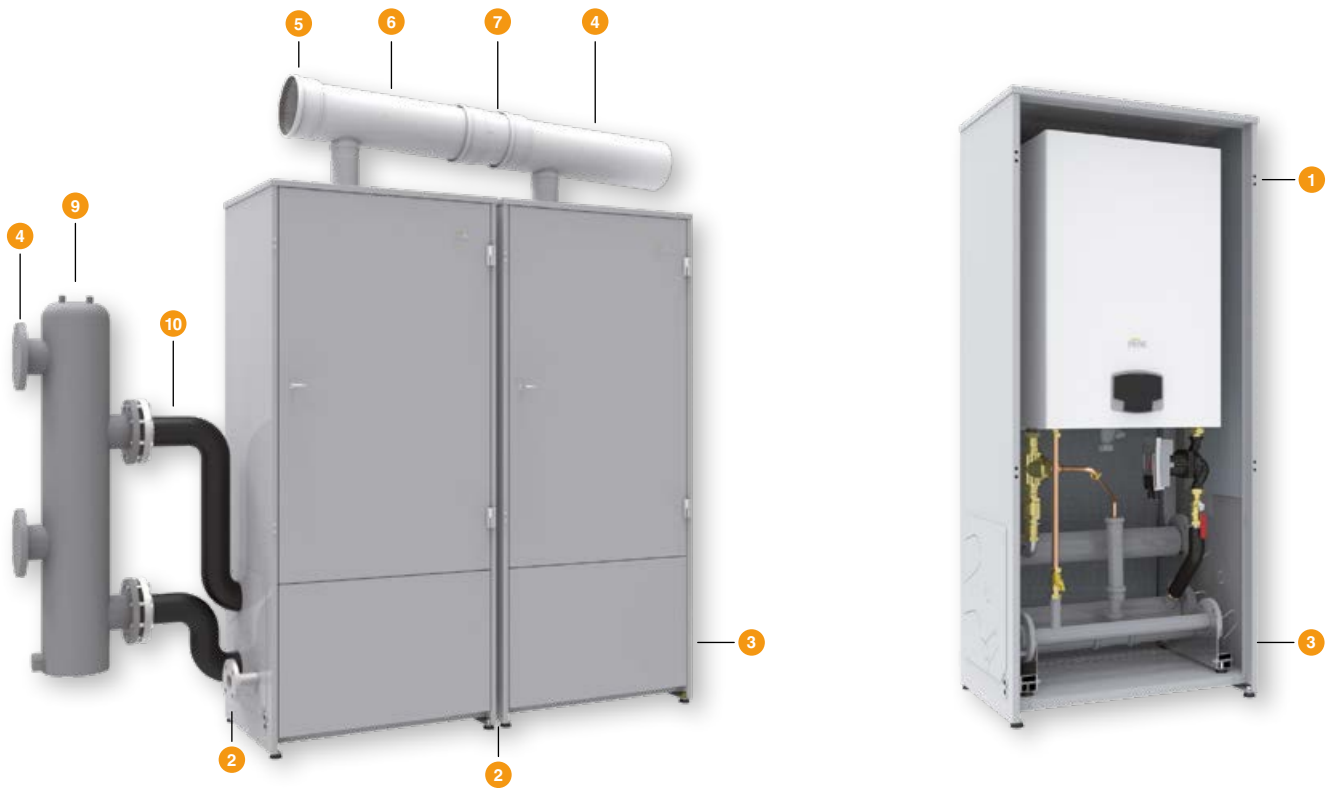

Notes: For the installation of the hydraulic compensator ¹¹, a connection kit is not necessary because the distance between the connections are the same of the boiler manifolds and can be connected directly to the flanges.

P _{out} (50/30°C)	MODULES Force B			Tot. modules	1	1	1	2	3	4	5	6	7	8	9	10	9	10
	0MDDCAWA	0MDDEAWA	0MDDFAWA		Kit adaptors flanged	Blind flange kit DN65	DHW probe and/or system delivery (5 mt)	Flue gas manifold (start)	Flue gas manifold (extension)	Flue gas manifold (connection)	Flue gas terminal (for single installation)	Hydraulic separator DN65 (until 300 kw)	Installation kit for hydraulic separator (until 300 kw)	Hydraulic separator DN100 (until 600 kw)	Installation kit for hydraulic separator (until 600 kw)			
77	1			1	1	1	1							1	1	1		
117		1		1	1	1	1							1	1	1		
148			1	1	1	1	1							1	1	1		
154	2			2	2	1	1	1	2	1				2	1	1		
194	1	1		2	2	1	1	1	2	1				2	1	1		
234		2		2	2	1	1	1	2	1				2	1	1		
265		1	1	2	2	1	1	1	2	1				2	1	1		
296			2	2	2	1	1	1	2	1				2			1	1
351		3		3	3	1	1	1	3	2				3			1	1
373	1		2	3	3	1	1	1	3	2				3			1	1
413		1	2	3	3	1	1	1	3	2				3			1	1
444			3	3	3	1	1	1	3	2				3			1	1
468		4		4	4	1	1	1	4	3				4			1	1
530		2	2	4	4	1	1	1	4	3				4			1	1
561		1	3	4	4	1	1	1	4	3				4			1	1
592			4	4	4	1	1	1	4	3				4			1	1



HYDRAULIC SEPARATORS

Characteristics

The hydraulic separator guarantees independence between the primary circuit (generator) and the secondary circuit (system) without any disturbance or interference between them. The separator is proposed complete with deaerator, sludge separator and is fully insulated.

CHARACTERISTICS: Max operating pressure: 6 bar - Temperature range: 0 -100°C - Connections: DN 65 / DN 100

HYDRAULIC SEPARATOR FOR INSTALLATIONS UP TO 300 KW



Hydraulic separator DN 65
042078X0



DN 65 separator hydraulic
connection manifolds
042079X0



HYDRAULIC SEPARATOR FOR INSTALLATIONS UP TO 600 KW



Hydraulic separator DN 100
042080X0



DN 100 separator hydraulic
connection manifolds
042081X0

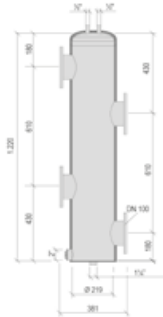

PRESSURE DROPS

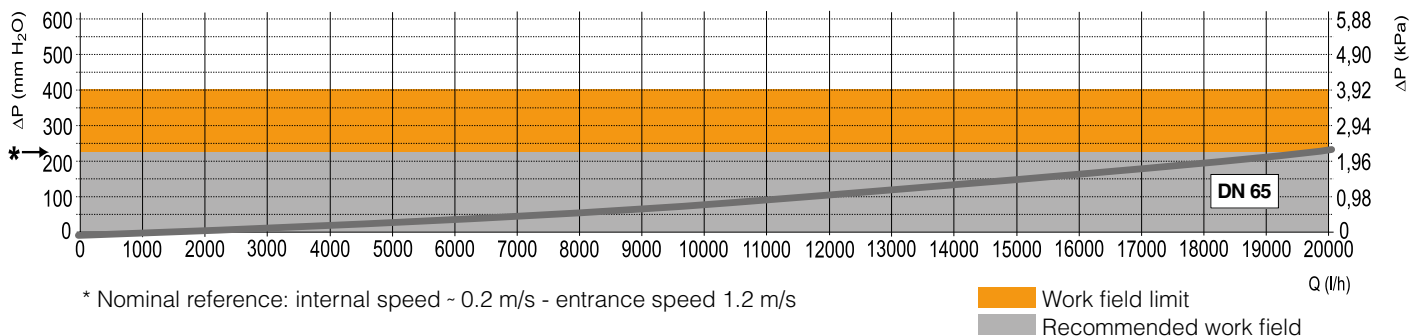

DIMENSIONS AND TECHNICAL DATA

MODEL		DN 65	DN 100
Flow rate	m ³ /h	18	30
Capacity	l	21	46
Max temperature	°C	100	
Max pressure	bar	6	
Raw material	-	ST37.1 steel	
Insulation	-	EPP Black - 40 g/l	



ACCESSORIES

To complete installation



Temperature control - Water treatment - Plates



ø 100 flue gas terminal
1KWMA29K



Neutralisers



90° bend kit in PPS
ø 100 mm **041077X0**



Kit for management with thermostat (not supplied) of a DHW storage tank (for heating only boilers)
013017X0



1 m MF mm PPS flue gas duct kit
ø 100 **041073X0**



Additional sensor for storage tank and/or system delivery for cascade configurations with and without hydraulic separator
2 m cable **1KWMA11W** - 5 m cable **043005X0**



Flue gas terminal (for single installation)
041094X0



SHE
Heat exchangers with brazed steel plates



PHE
Heat exchangers with inspectable steel plates



Outdoor probe
013018X0



NOTES

A series of horizontal dotted lines for writing notes.



NOTICE FOR SALES AGENTS:

With a view to constantly improve its production range and customer satisfaction levels, the Company hereby specifies that aesthetic and/or dimensional features, specifications and accessories may be subject to changes.

Please place the utmost care to ensure all technical and/or sales documents (lists, catalogues, brochures, etc.) provided to the final Customer are updated according to the latest edition.

Ferroli SpA

37047 San Bonifacio (VR) Italy - Via Ritonda 78/A

tel. +39.045.6139411

fax +39.045.6100233

www.ferroli.com

export@ferroli.com